



Chemical Injection Pump

Installation and Service Manual

www.solarproductionequipment.com

Pump Model
P-075-M1/8-1750-12-SS-HP



C US
CLASS 1 DIV 1
or equivalent

Table of Contents

- Overview** **3**
 - Pump Specifications 3
- Installation instructions** **4**
 - Location of pump 4
 - Tubing Connections 4
 - Suction line 4
 - Discharge line 4
 - Electrical Connections 5
 - Priming the pump 5
- Routine Maintenance and repair** **7**
 - Monthly maintenance check 7
 - Parts Replacement or Rebuild of Pump Head Assembly 7
- Warranty Note** **14**

Table of Figures

- Figure 1: Typical Installation Diagram 6
- Figure 2: Assembly diagram (1) 11
- Figure 3: Assembly diagram (2) 12
- Figure 4: Typical Pump Assembly 13

Overview

Chemical injection pump

SPEC Chemical Injection Pumps are used to accurately metre and inject chemicals at well sites and production facilities. The pump is a directly opposed, dual-head, reciprocating piston design. The pump uses an eccentric bearing mounted directly to the end of the prime mover shaft that fits into a close tolerance indentation machined into the middle section of the reciprocating piston assembly. The bearing moves in an orbit as the motor spins, driving the piston shaft back and forth between the horizontally opposed pump heads. As a result of this motion, the pump simultaneously draws fluid into one pump head while pressurizing the other pump head. As the bearing moves through 180 degrees, it reaches the end of travel, causing the piston assembly to reverse direction.

The pump consists of two directly opposed pump heads positioned between the suction and discharge manifolds. Two Poppet valves are located at each end of the pump, between the suction and discharge manifolds and the pump heads. As the piston plunger moves past the seal and into the bore of the pump head assembly, one poppet valve is forced open, while the other is forced closed. This causes fluid to be driven into the discharge manifold (pressure or discharge stroke). As the eccentric bearing drive assembly rotates through 180 degrees on the end of the motor shaft, the piston assembly changes direction and draws back from the pump head. The poppet valve operation reverses direction and the fluid is drawn from the suction manifold into the pump head (suction stroke).

At the same time one of the horizontally opposed pump heads is pressurizing, the other pump head is drawing fluid from the reservoir, creating the concurrent suction and discharge.

The pump repeats this operation, one discharge stroke and one suction stroke, at each of the opposing pump heads, for every 360-degree (full-circle) rotation of the motor. The motor is rotating at 1750RPM, equalling 3500 discharge strokes per minute.

Pump Specifications

Type	Dual-head reciprocating piston
Voltage	12 VDC
FLA	14
Maximum static pressure	3000 PSI
Maximum operating pressure	2000 PSI Max Consult factory for applications beyond 1000 PSI
Pumping Capacity	Maximum 1500 liters/day
Classification	Class 1, div 1, Group D, T2D

Installation instructions

Location of pump

We recommend that you locate the pump as close to the controller/battery enclosure as possible, while still observing the area classification as dictated by section 18 of the Canadian Electrical Code and any local code requirements. It is important to remember that the pump assembly is certified Class 1 Div 1 group D while the SPEC controller/battery enclosure is certified Class 1 Div 2. Since this is a 12 Volt DC-powered system, it is necessary to keep the distance between the pump motor and the batteries as short as possible (maximum 20 feet) to limit the line losses and maximize the pumps' output. The pump is a gravity fed design and therefore must be located below the fluid reservoir from which it draws.

Tubing Connections

There are two manifolds on the pump, one for suction and one for discharge. Each manifold is common to both the opposing pump heads. There is one threaded entry at each end of both the suction and the discharge manifolds to allow for installation flexibility in the field. The discharge manifold and its entries are always located at the top of the pump body and the suction manifold and its entries are located at the bottom.

Suction line

The intake or suction connection is identified by an **"S"** stamped into the metal next to the ¼ threaded entries on the suction manifold. The entries come from the factory with a stainless steel plug installed at one end. Configure the plug to facilitate the desired suction entry and connect the suction line. It is strongly recommended that the suction line have an appropriate medium filter installed directly ahead of the pump entry to ensure that particles do not enter into the pump head and plug up the poppet valves.

Discharge line

The discharge connection is identified by a **"D"** stamped into the metal next to the plugged ¼ threaded entries on the discharge manifold. Again, configure the plug to facilitate the desired discharge entry and connect the discharge line. The discharge line installation should always include a pressure safety valve (PSV) and recycle loop to insure discharge pressure is limited to a safe level. It is also necessary to place an in-line check valve in the discharge line, as close to the pump head as possible, to eliminate leak back and maximize pump efficiency.

Electrical Connections

The pump is a 12 volt direct current machine.

Polarity of the connections is critical for proper functioning of the pump.

Do not run the pump with reversed polarity as significant damage will occur.

The leads are clearly marked for polarity:

“+” is to be connected to the positive of the controller load terminals.

The positive lead is also identified with a red band.

“-” is to be connected to the DC negative bus.

The motor feeders should be properly fused for protection as per the Canadian Electrical Code.

Priming the pump

The pump is designed to be self-priming and incorporates a flooded section design that requires some “fluid head” to operate effectively, therefore the pump should not require any special attention to achieve priming.

However, if you do encounter difficulty, you can bleed the plug opposite the discharge entry that you are using and allow the air to escape the manifold until the fluid stream is solid. Tighten the plug and the pump should now be primed.

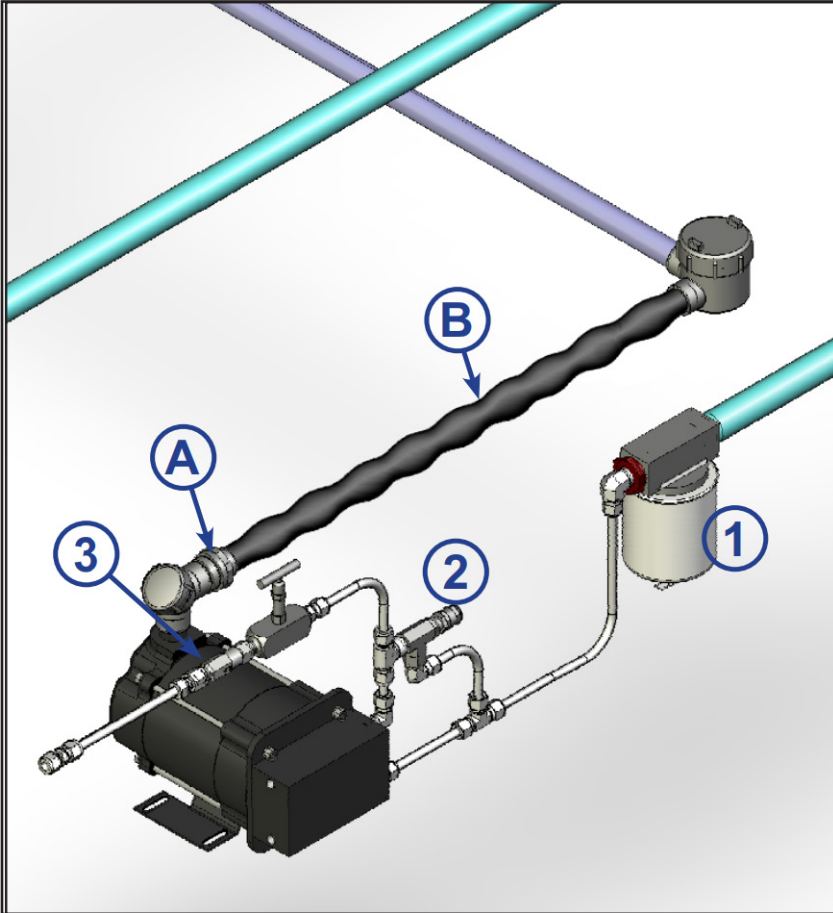

Figure 1: Typical Installation Diagram

Minimum instrumentation tubing and accessory requirements for proper operation of the pump are:

1. A suitable **medium filter** (440 micron filter) placed in the feed line between the sight glass and suction port. The filter should be as close as possible to the suction port of the pump.
2. A **pressure safety valve (PSV)** positioned in the discharge line, as close as possible to the discharge port of the pump, configured so that the discharge line pressure can be safely released back into the suction line in the event of a PSV valve release.
3. An **inline check valve** placed in the discharge line as close as possible to the discharge port of the pump and after the Pressure Safety Valve (PSV).

Typical layout for the electrical feed to pump must incorporate:

- A.** A CSA Class 1 div 1 electrical fitting, approved for terminations to connect the motor and conduit feed system. The motor is factory sealed and employs an inch rigid nipple for connection to the fitting.
- B.** A CSA Class1 div 1 approved flexible conduit or HL approved Teck Cable must be installed to allow for vibration as per the applicable codes.

Routine Maintenance and repair

SPEC pumps are designed for years of reliable service with minimal maintenance. All maintenance that is necessary must be carried out by qualified technicians. Ensure all power is off and appropriate lockout measures are in place prior to starting any maintenance activity.

Monthly maintenance check

Piston plunger bearing inspection

- Remove the four allen screws that hold the pump nameplate.
- Inspect the piston plunger cavity for debris and remove any foreign objects or debris.
- Apply a small amount of grease to the reservoir pad.
- Reinstall the pump nameplate

Parts Replacement or Rebuild of Pump Head Assembly

The only wear parts in the pump are the Seals, O-rings, piston assembly and bearing. Various replacement kits are available from SPEC.

This type of maintenance should always be done by a qualified instrumentation technician in a clean controlled shop environment.

The drawings on pages 9-10 show an expanded view of the pump assembly.

Do Not reuse lock washers when rebuilding pump. New lock washers are provided in the kit.

To remove and disassemble the pump fluid head assembly

1. Remove the pump fluid head assembly (fluid head only) from the motor mounting plate assembly by removing the four ¼" x ½" Socket Head Cap Screw (SHCS) fasteners and lock washers that hold the fluid head to the mounting plate. **Leave the mounting plate on the motor as it will be required for proper alignment of pump's fluid head during re-assembly.**
2. Separate the suction and discharge manifolds from the pump bodies by removing the eight ¼" x 1" SHCS fasteners and discard the lock washers (new lock washers are provided in the rebuild kit).
3. Separate the pump bodies from the piston assembly by pulling them apart gently.
4. Remove the seal retainers and then remove the seals, poppet valves, and O-Rings.
5. Inspect and thoroughly clean all pump components in preparation for reassembly. Soak poppet valves in solvent and then blow them out to ensure they are free of debris

To replace O-rings and seals:

Do not attempt to install new seals with out a SPEC seal installation tool (see picture below)



1. Remove pump fluid head from pump motor as per the above.
2. Disassemble as per above and note the orientation of the poppet valves.
3. Discard old O-rings and seals
4. Thoroughly clean all components. Blow out poppet valves, pump bodies, and manifolds in preparation for re-assembly.
5. Press the new o-rings into the depression in the pump body. (Image #10)
6. Seals: Carefully remove the old seals using the piston assembly to gently pry out the seal (Image #2), ensuring you do not scratch or mark the seal seats.
7. Insert the new seals into the pump body using the SPEC seal insertion tool provided in the kit and press the seal into place. **Note: the spring side of seal is placed toward the pump body).**
8. Next reinstall the seal retainers

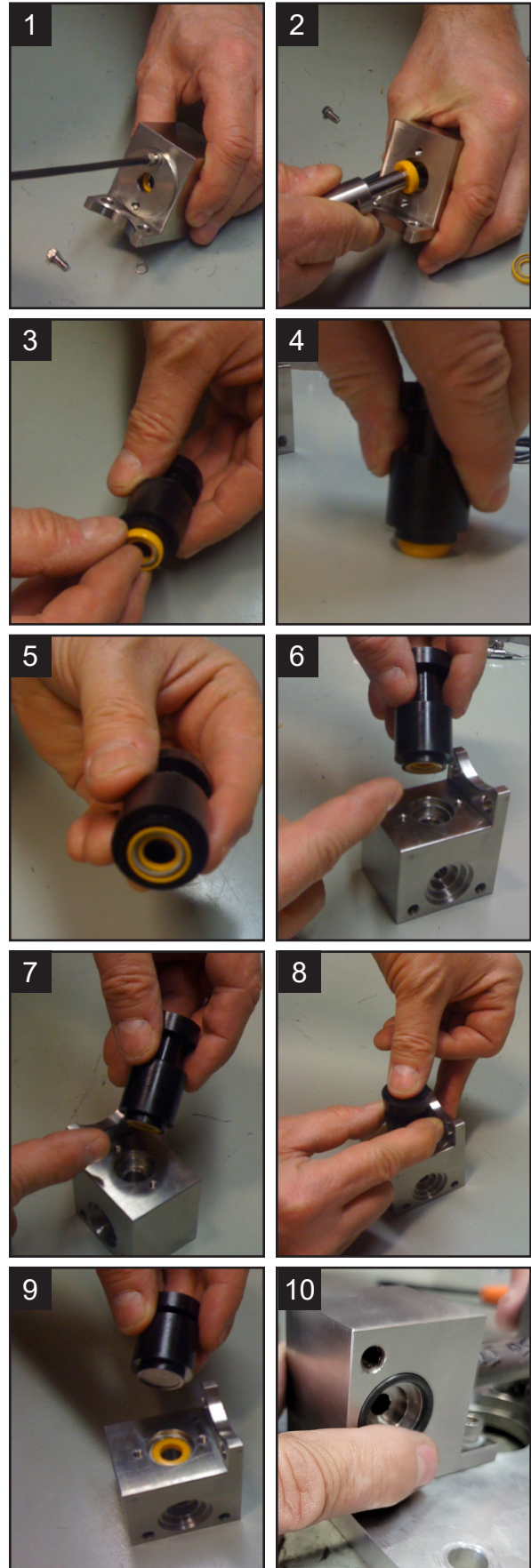

Re-assembly of the Pump Head Assembly

1. Insert the piston assembly into the seal bores of the two opposing pump heads and then gently press together (Image #1).
2. Install the O-Rings in the pump bodies (Image #2)
3. Install the poppet valves ensuring proper orientation (see illustrations to the right)
4. Align the poppet valves / pump bodies with the suction and discharge manifolds openings
5. Use a C clamp to press together and hold the manifolds and pump bodies in alignment (image #5). You must ensure that the manifolds and pump body components are assembled to **lie flat** against the mounting plate for reassembly. **Do this by assembling the manifolds and bodies on a flat, hard surface to ensure proper alignment of the piston to the seal bores.**

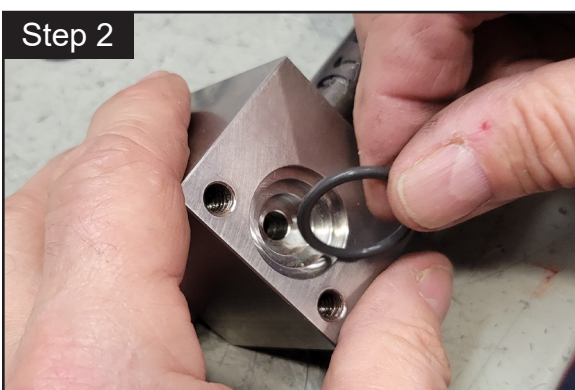
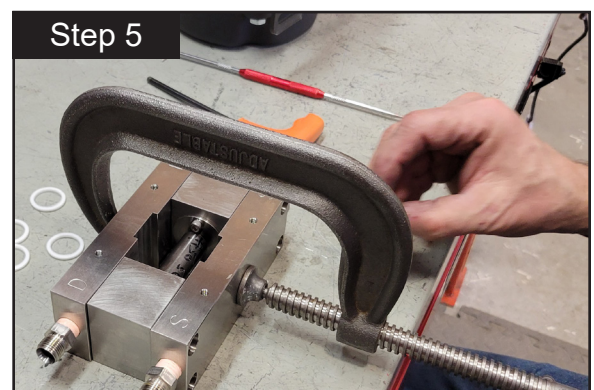
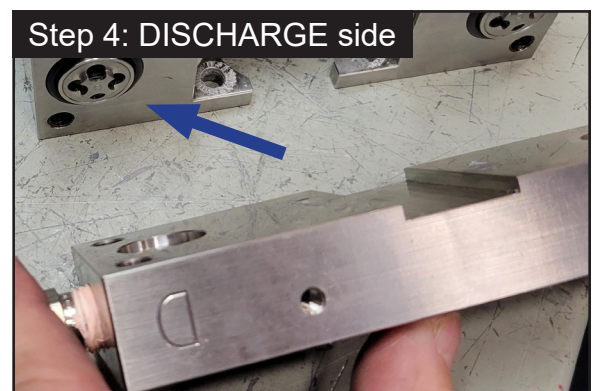
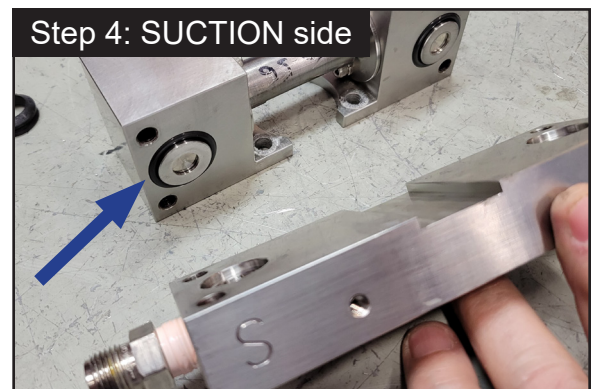

6. Install all eight manifold bolts utilizing anti seize and the new lock washers provided in the rebuild kit. Tighten the manifold bolts to the proper specified torque for the fasteners utilized (consult the factory for exact torque). Remove the clamp.
7. Grease the Drive bearing assembly on the end of the motor shaft
8. To reinstall the fluid head to the mounting plate you must first align the indentation in the piston assembly with the drive bearing on the end of the motor shaft for the fluid head to drop into place onto the mounting plate.

This is easily accomplished by turning the drive bearing / pump motor shaft clockwise until the small hole in the bearing's center piece and the center of the motor shaft are aligned vertically with the small hole at the top (See **8-A** on the right).

Next move the piston assembly in its horizontal travel in the fluid head until the indentation of piston assembly is centered (the mid point of piston travel) in the fluid head's center opening (see image **8-B** on the right). This will align the piston indentation with bearing assembly and allow the fluid head to drop into place flush with the mounting plate. You may have to gently wiggle the fluid head to get it to drop but it will go.

DO NOT force the fluid head onto the mounting plate. Doing so will damage the pump components and will cause damage to the seals.

9. Install and tighten the four 1/4" x 1/2" SHCS fluid head mounting fasteners into the mounting plate to the proper specified torque for the fasteners utilized (consult the factory for torque value)
10. Reinstall the cover plate with the four fasteners you previously removed.



Step 8-A: Turn shaft clockwise to align vertically (in "12 o'clock" position)

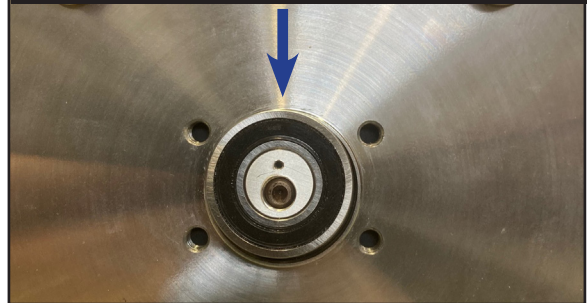

Step 8-B: Align piston to center position (mid point of piston travel)

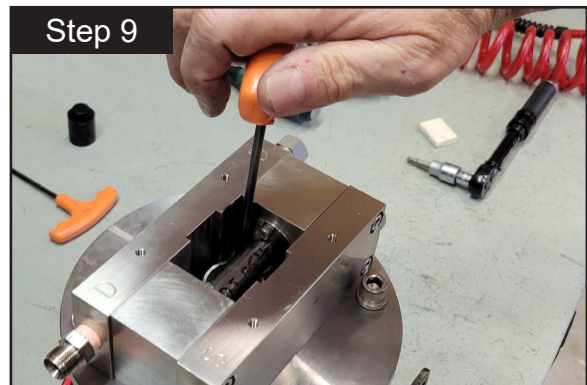
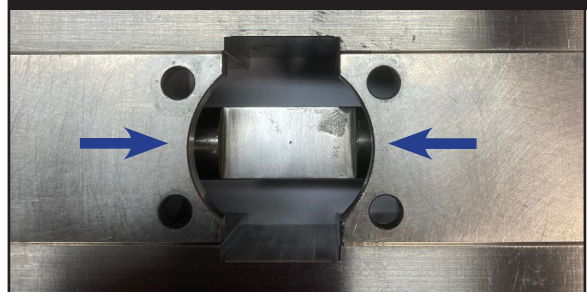

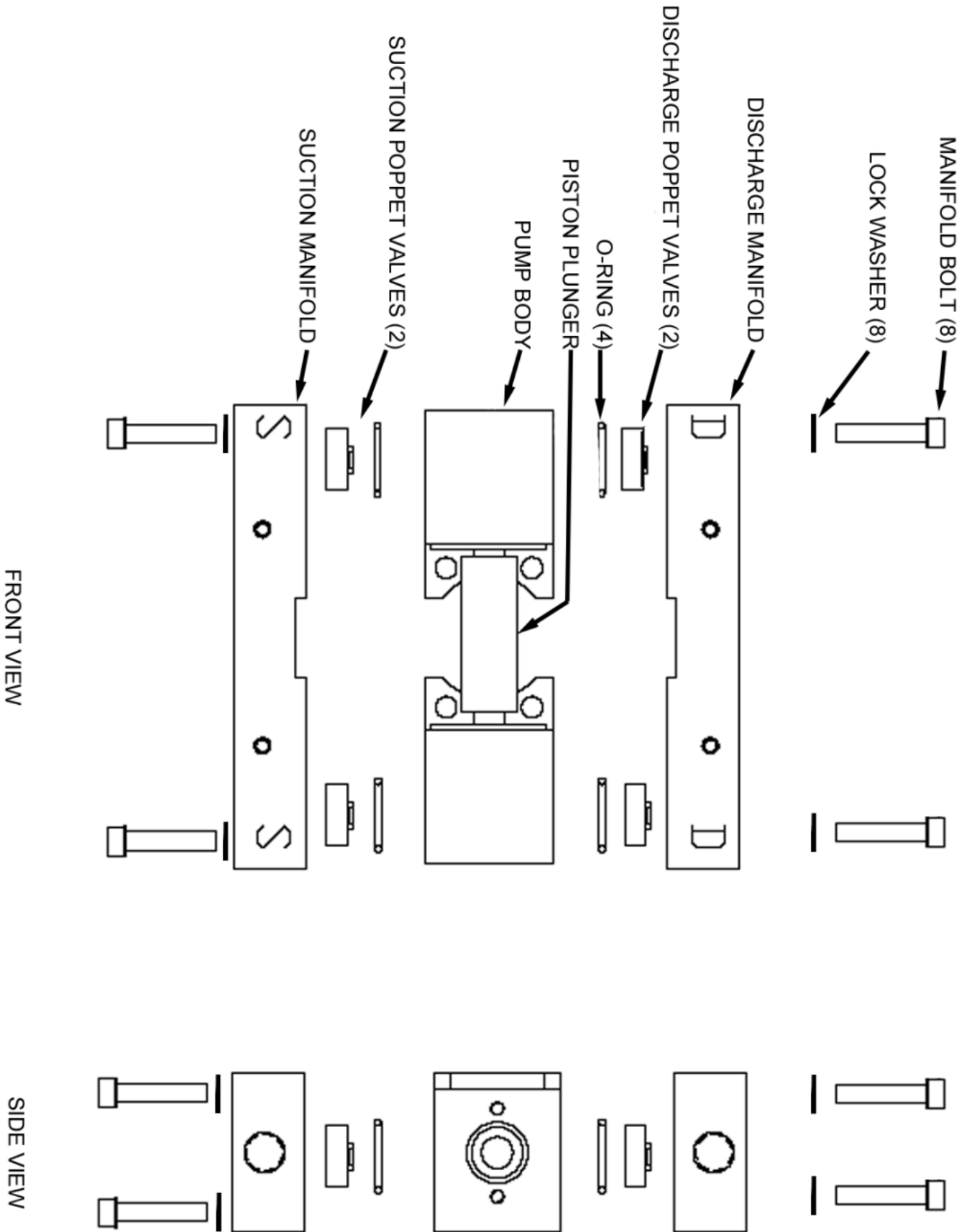

Figure 2: Assembly diagram (1)

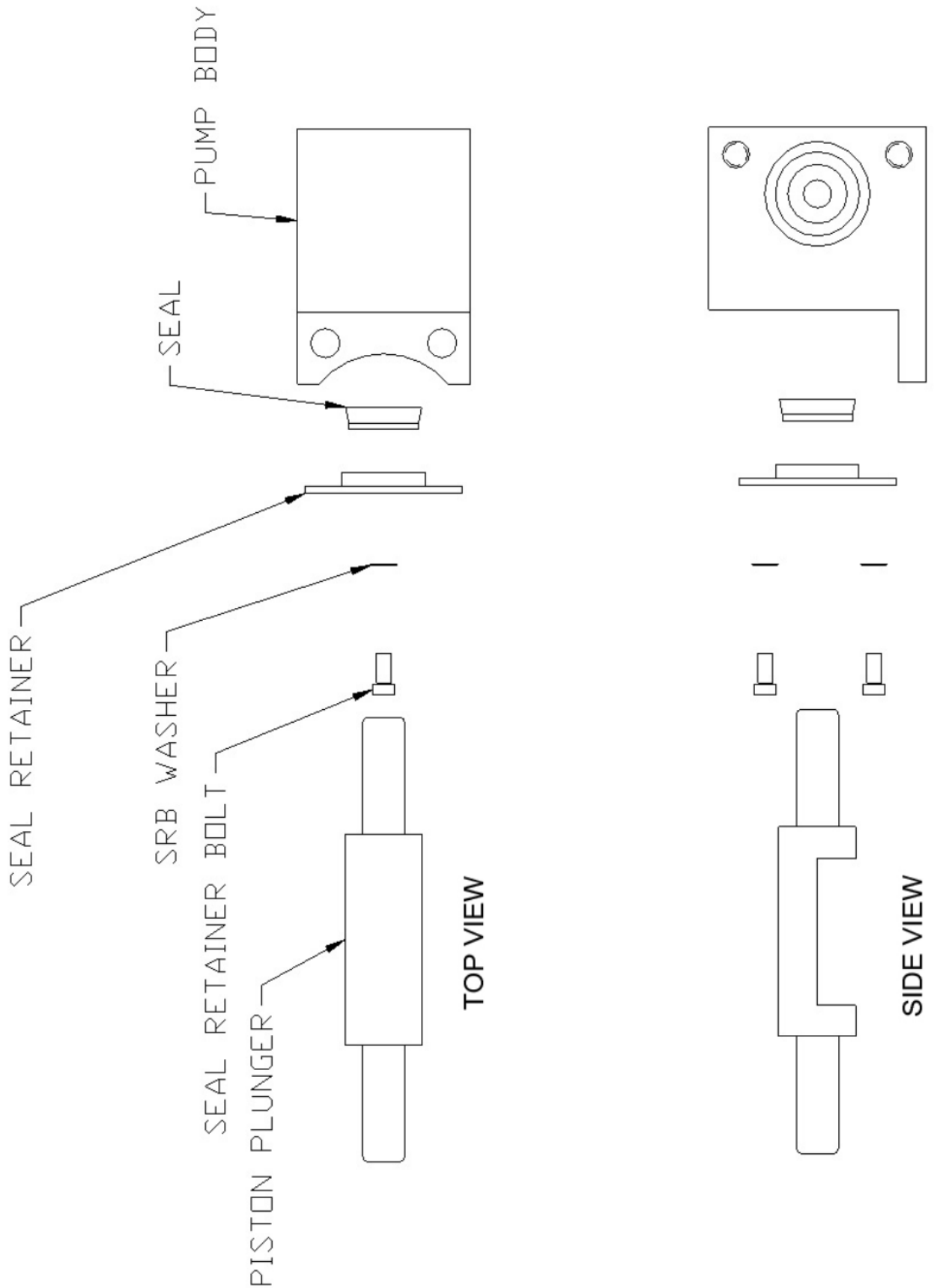

Figure 3: Assembly diagram (2)

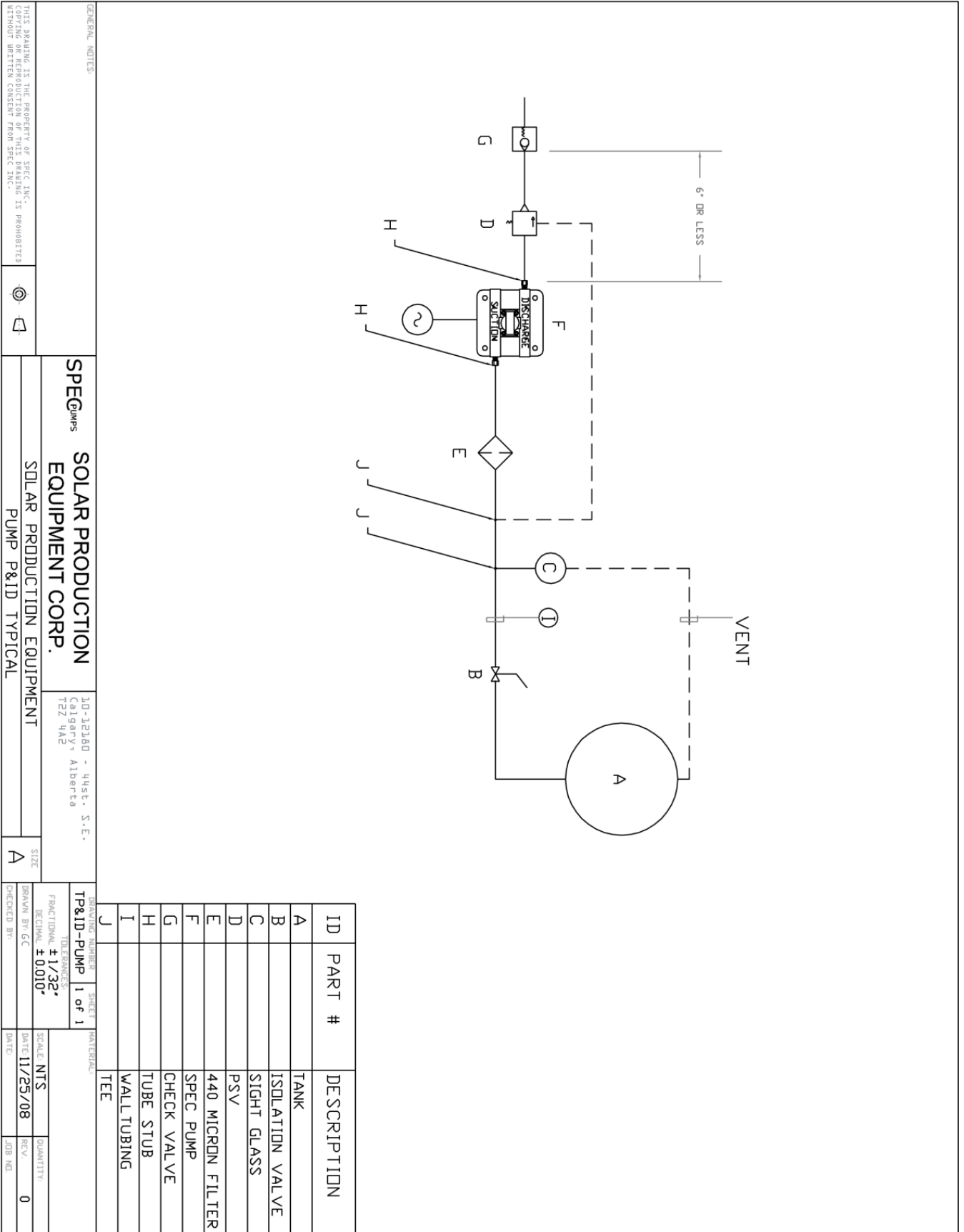

Figure 4: Typical Pump Assembly

GENERAL NOTES:		THIS DRAWING IS THE PROPERTY OF SPEC INC. COPYING OR REPRODUCTION OF THIS DRAWING IS PROHIBITED WITHOUT WRITTEN CONSENT FROM SPEC INC.	
SPEC PUMPS SOLAR PRODUCTION EQUIPMENT CORP. SOLAR PRODUCTION EQUIPMENT PUMP P&ID TYPICAL		10-12180 - Hqst. S.E. Calgary, Alberta T2Z 4A2	
TOLERANCES: FRACTIONAL ± 1/32" DECIMAL ± 0.010"		SHEET 1 of 1 MATERIALS:	
SCALE: NTS DATE: 11/25/08 CHECKED BY:		QUANTITY: 0 REV:	

Warranty Note

Only “Solar Production Equipment Corp (SPEC) Sellers Terms and Conditions of Sale” and “Solar Production Equipment Corp (SPEC) Limited Warranty” shall apply to Solar Production Equipment Corp (SPEC) products. No other Terms and Conditions or Warranty apply, is implied, offered, or accepted regardless of any statement to the contrary in any document, Request for Quotation or Customer’s Purchase Order. Solar Production Equipment Corp expressly rejects any and all other Terms and Condition or Warranty stipulated in any RFQ or Purchase order document.

Please see the documents on the Solar Production Equipment Corp web site (www.solarproductionequipment.com) located under the “Legal” heading on the “Resources” page.

- Solar Production Equipment Corp (“SPEC”) limited Warranty – Version 3.0, Nov 1, 2023
[\[download from solarproductionequipment.com\]](#)
- Solar Production Equipment Corp (“SPEC”) Terms and Conditions – Version 3.0, Nov 1, 2023
[\[download from solarproductionequipment.com\]](#)

Thank you for choosing Solar Production Equipment Corp.

SPEC

Solar Production Equipment Corp

#66-64089-393 Ave East
Okotoks, Alberta
T1S0L1

Phone: (403) 730-5951

24 hour emergency service: **(403) 990-5558**

Account inquiries (payables and receivables):
admin@solarproductionequipment.com

Sales or technical inquiries and field assistance:
gclark@solarproductionequipment.com